

BLACK ADDER

PCB V1.0 BUILDER'S MANUAL

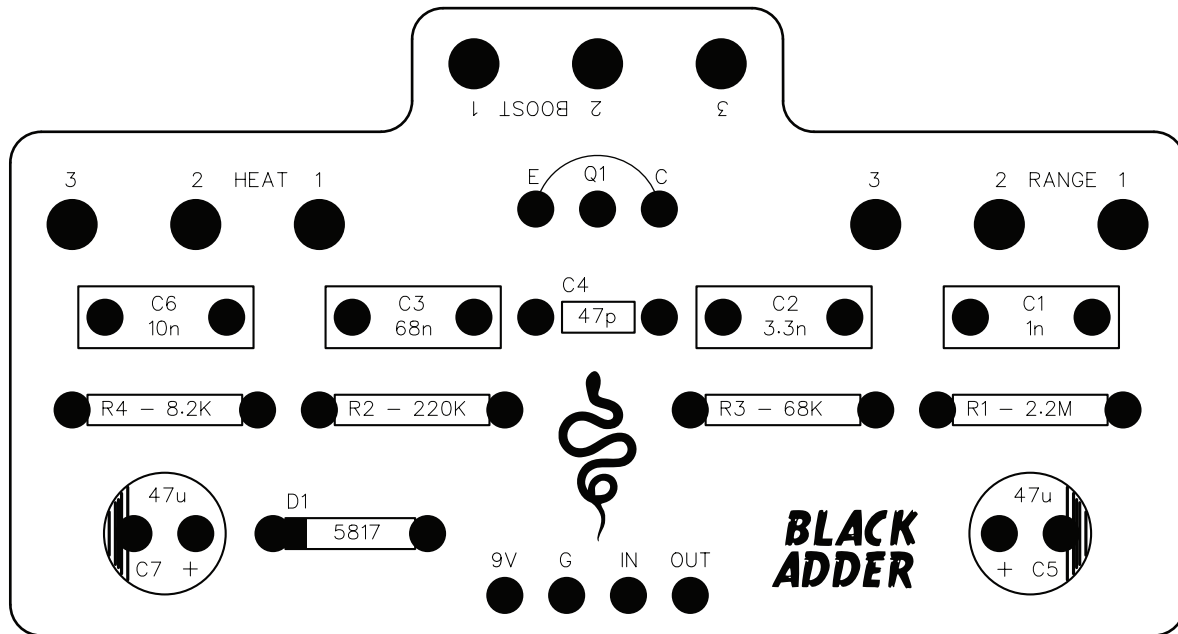

TABLE OF CONTENTS

1. Title Page
2. General Build Notes
3. 16mm Pot Adapter Board Info
4. 3PDT Daughterboard Info
5. Circuit Info
6. Bill of Materials
7. Onboard Wiring / Component Layout
8. Offboard Wiring (3PDT PCB)
9. Offboard Wiring (No 3PDT PCB)
10. Schematic
11. Drill Template



PCB boards designed to allow direct mount
90 degree potentiometers

Dimensions (W=48.26mm x H=25.78mm)
Recommended enclosure 125B

Drill Template: HT125B-3K-08, HT125B-3K-12

For a downloadable PDF copy of this manual, visit www.hammondtoneworks.com/support

DISCLAIMER:

All board layouts have been tested and verified. While I do offer a guarantee on the functionality of purchased PCBs, there is an understood assumption that the end user (you) have the knowledge and skill required to assemble the product and accept any risk involved with assembling the provided boards or parts. This understood skill level includes knowing how to properly solder, troubleshooting steps, etc. If you have any questions concerning any Hammond Toneworks products, feel free to send a message on the platform of purchase, or contact support at support@hammondtoneworks.com

COMMERCIAL USE:

You may use Hammond Toneworks PCBs in commercial projects as long as the completed project is not sold as a Hammond Toneworks branded pedal, and the model name of the PCB is not used on the enclosure. Crediting the use of the PCB is not required. PCBs are not be resold as an item themselves.

Hammond Toneworks PCB boards are manufactured to accomodate the following recommended components

- Resistor:** 1/4w metal film or carbon film resistors
(7.62mm lead spacing on all resistor connections)
- Film Cap (B):** Film box type capacitor
(5mm lead spacing unless otherwise noted)
- Cer Cap (M):** Monolithic ceramic capacitor
(5.08mm lead spacing, ceramic disc capacitor can be used as a substitution)
- Cer Cap (D):** Ceramic disc capacitor
(2.54mm lead spacing)
- Elec Cap:** 25V Electrolytic Capacitor recommended, unless otherwise noted (50V caps recommended if using over 9V power)
(2.54mm lead spacing)
- Transistor:** All transistor holes are spaced to 2.54mm for easier soldering
(2.54mm lead spacing)
- Diode:** 6.32mm-7.62mm lead spacing and 0.9mm hole diameter on PCB
- Pots:** Potentiometers are to be connected to the effect board directly. Common 16mm right angle pots are recommended.
(5mm lead spacing) NOTE: Potentiometer hole diameters are sized to allow pots to be connected via wire if preferred.
- Wires:** Wiring connection holes are drilled to 1mm diameter and are spaced 2.54mm apart.
Use of 24G wire is recommended for easy assembly

RECCOMENDED ASSEMBLY ORDER**1. EFFECT BOARD ASSEMBLY**

- Solder small components first (resistors, diodes, etc) then work your way up to soldering the tallest components , then potentiometers, and finally the connection wires to the 3PDT daughter board (if used) NOTE: This is the general order of assembly, if any particular board is assembled easier using a different oder, it will be noted in the respective build docs.

2. OFFBOARD WIRING

- Refer to the recommended offboard wiring methods on pages 8 or 9 (depending on your preference)

16mm PCB PIN POTENTIOMETER ADAPTER BOARD

Optional potentiometer adapter boards are available for purchase directly or via our Reverb store. These allow a secure connection with potentiometers that have a straight pcb pin type connection and to help organize offboard wiring. **These adapters are optional, and only recommended if the potentiometers in use do not have solder lugs or are unable to be connected directly to the pcb.**

NOTE:

It is easier to attach the wires to the adapter boards first, then solder the potentiometer to the adapter board **LAST**. Attach the wires to the front side of the PCB with the Hammond Toneworks logo, and attach the potentiometer to the rear side of the PCB that is marked with "POT THIS SIDE".

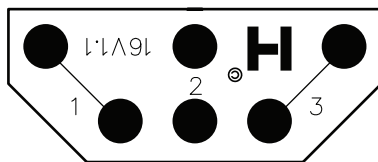

FRONT

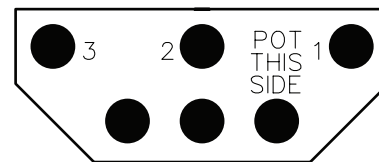

REAR

ASSEMBLED

(SHOWN WITHOUT WIRING)

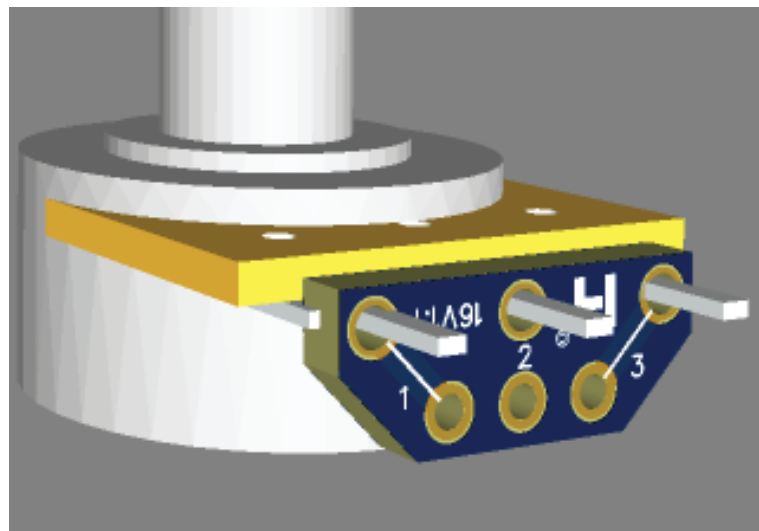
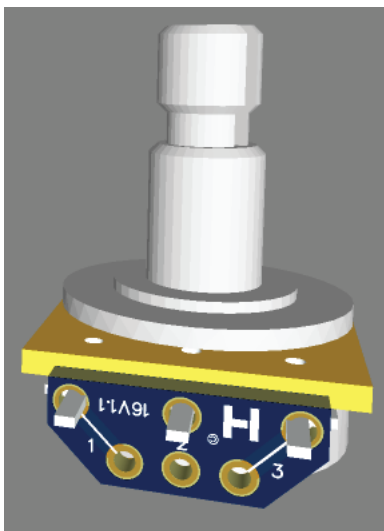

3PDT DAUGHTERBOARD PCB

Included with your board is an optional 3PDT daughterboard PCB (compatible with enclosure sizes 1590B and larger) to help organize offboard wiring and simplify connections to the main circuit. Follow the wiring diagrams on pages 7 & 8 if using the 3PDT PCB daughterboard.

NOTE:

Attach all PCB connections and components first, then solder the 3PDT switch to the 3PDT PCB board **LAST**. This is necessary due to the fact that the switch itself blocks access to some of the onboard soldering points located on the daughterboard to save space. Assemble the components and wires to the front side of the PCB with the Hammond Toneworks logo, and attach the 3PDT switch to the reverse side of the PCB that is marked with "3PDT THIS SIDE" wiring points are labeled on both sides of the PCB for ease of assembly. This page references the current v2.3 PCB, the the older v2.2 PCB is the same except for the input hole location.

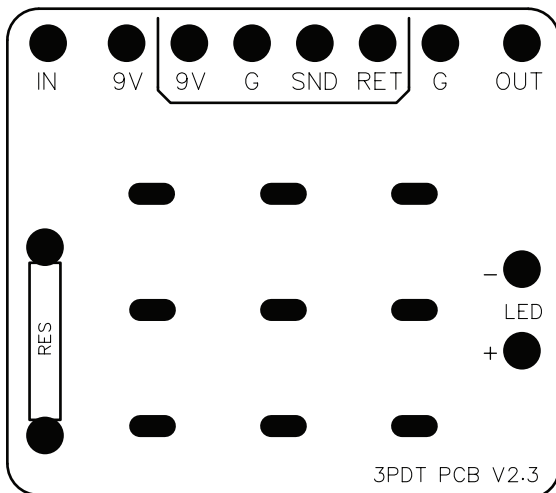

FRONT

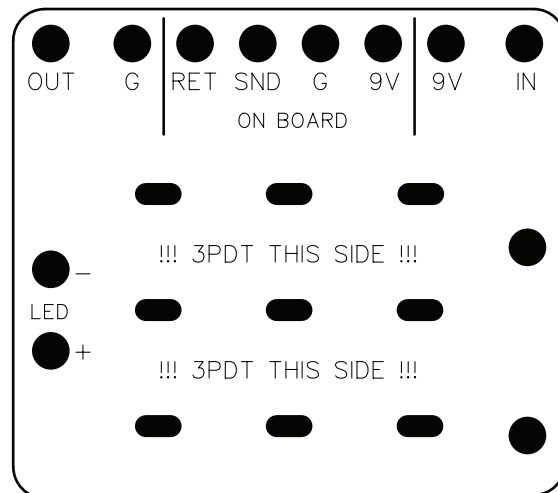

REAR

LAYOUT

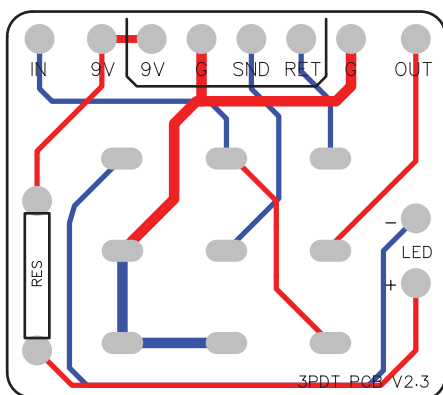

ASSEMBLED

(SHOWN WITHOUT WIRING)

BLACK ADDER

Based on the *Naga Viper**, which is in turn a usefully modified version of the classic Rangemaster booster circuit. Besides retaining it's vintage treble boosting characteristics, the Black Adder allows for the adjustment of the frequency range boosted, as well as the amount of dirt added when boosted. This opens up the possibility to boost your full signal instead of just treble frequencies. You can use the Black Adder as a clean boost, or to add some sizzle to your leads.

CONTROLS

RANGE:

The RANGE control adjusts the range of frequencies boosted. Turning clockwise will give a traditional treble boosted character. Turning the knob counter clockwise allows for more bass frequencies to be boosted as well.

BOOST:

The BOOST control adjusts the strength of the circuit output, turning clockwise will make the output louder, used for boosting amps and other pedals.

HEAT:

The HEAT control adjusts the amount of gain in the circuit itself, turning counter clockwise will yield a cleaner boost, while turning clockwise will yield a sound likened to a dirty boost.

NOTE: Like most boosters, the Black Adder is intended to be used as a tool in combination with other pedals or to boost an overdriven signal.

* Hammond Toneworks is in no way affiliated with Catalinbread Effects

BILL OF MATERIALS

RESISTOR		FILM CAP (B)		CER CAP (M)		ELEC CAP		TRANSISTOR		DIODE		POTS	
1	8.2k	1	1n	1	47p	2	47u	1	2N2222A	1	5817	1	A500K
1	68k	1	3.3n									1	B1K
1	220k	1	10n									1	B10K
1	2.2M	1	68n										

*NOTE: Off board components are not listed (indicator LED, input/output jacks, power input jack, footswitch)

SMALL COMPONENT TABLE

(Small components may be taped down here)

RESISTORS

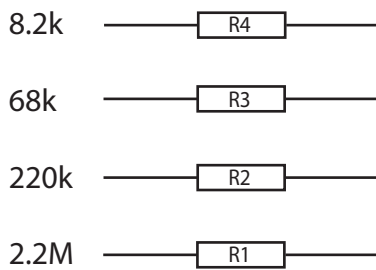

FILM CAPACITORS

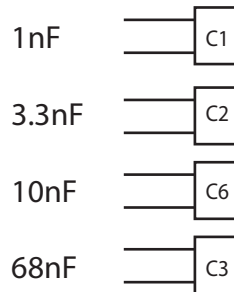

DIODES



ELECTRO CAPACITORS

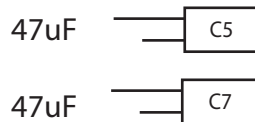

TRANSISTOR



CERAMIC CAPACITORS



Refer to the illustration below when attaching components to your PCB

(wire length, boards, and pots are not shown to scale. They have been sized to fit this page for illustration purposes)

Board mounted pots
(see page 7a for pot mounting)

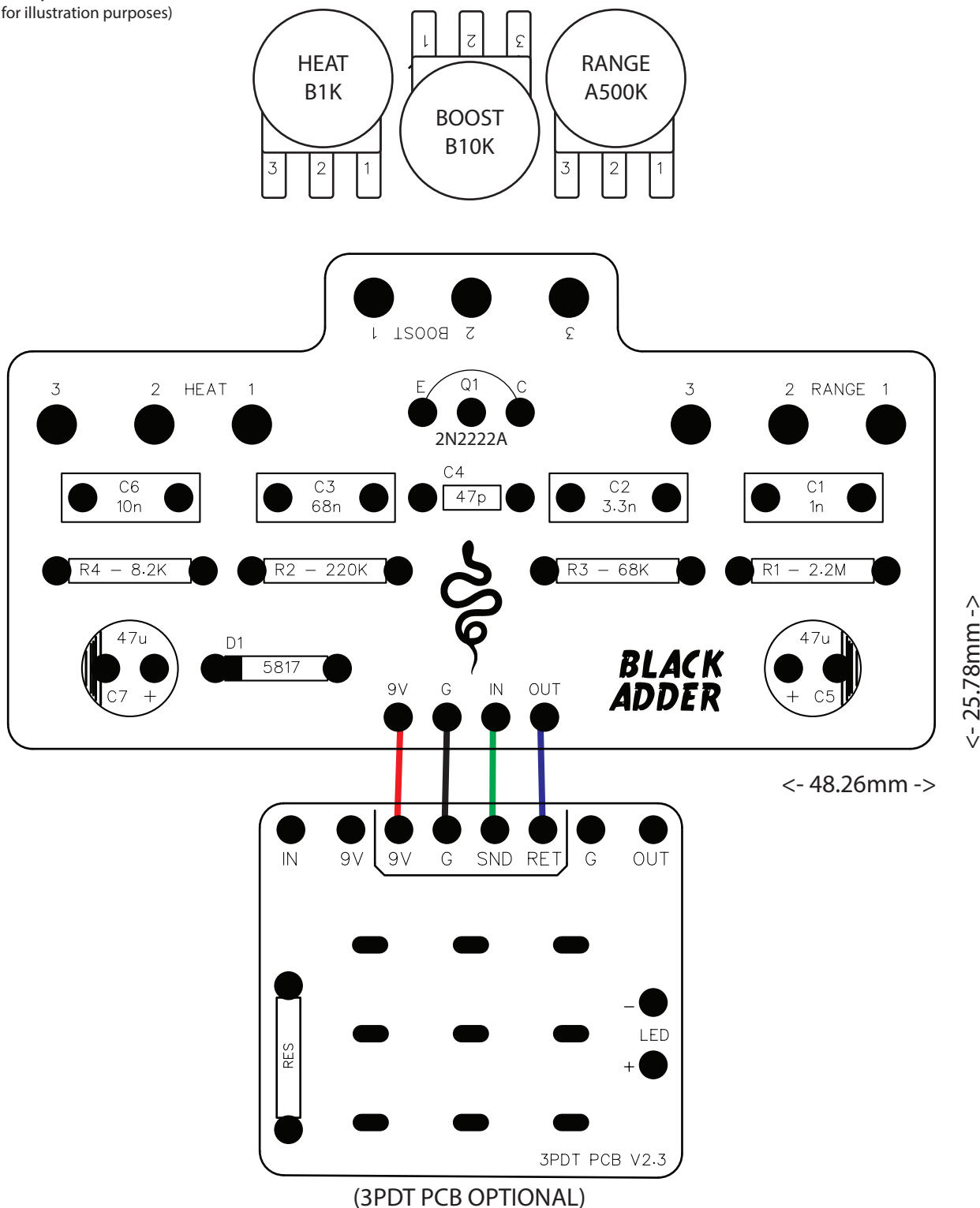

Bill of materials on page 6

Refer to the illustration below when attaching components to your PCB

BOARD MOUNTED POTS (PCB REAR VIEW)

(Pots are not shown to scale. They have been sized to fit this page for illustration purposes)

EXAMPLE VIEW

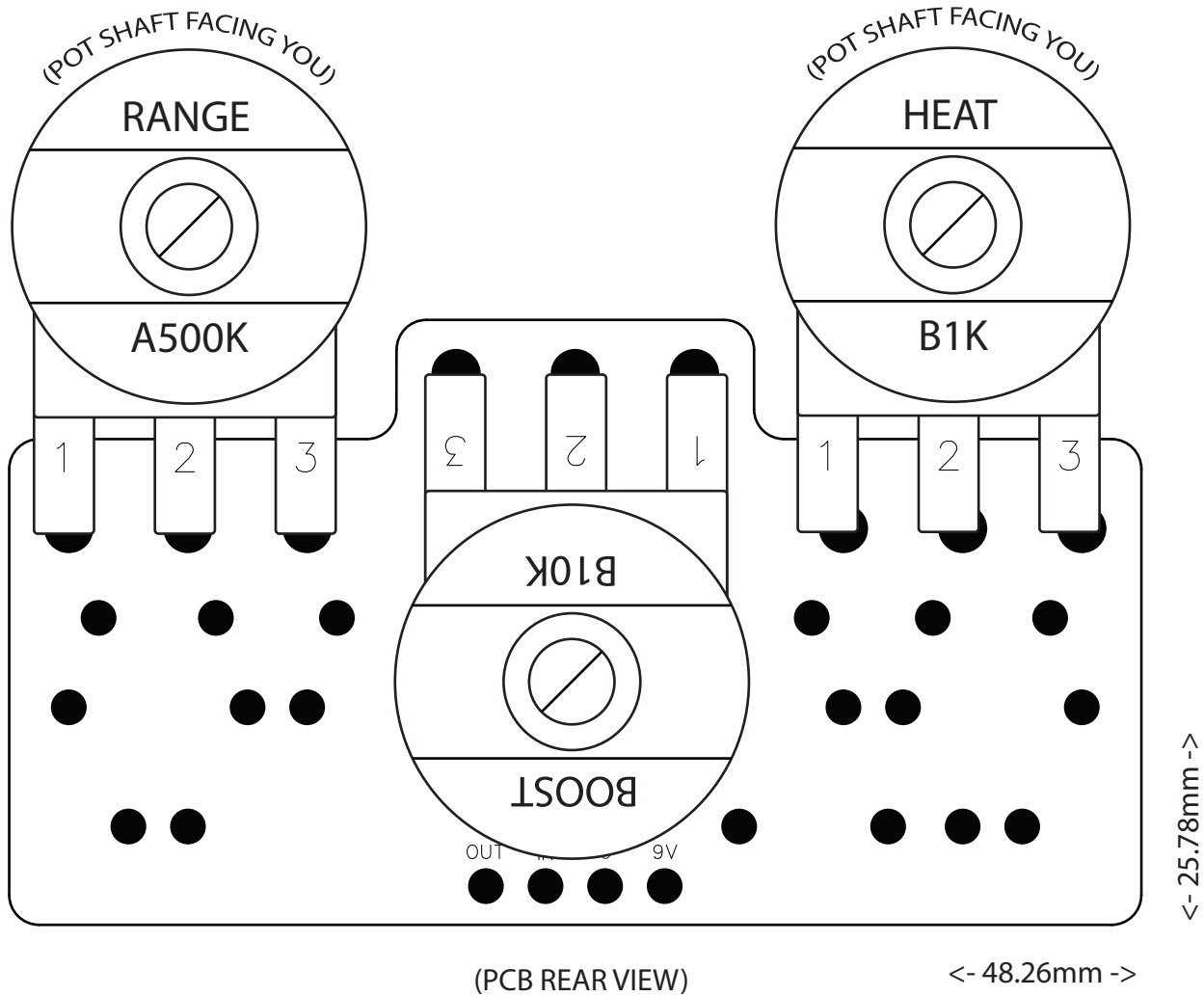
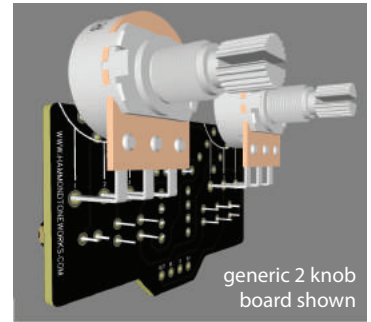

A 3PDT PCB board is included with your effect board to simplify the offboard wiring process. You may use your own method of offboard wiring if preferred. The illustration below is recommended if you are using the included 3PDT PCB. As long as the effect PCB receives the correct 9V, Ground, In, and Out connections, it will work properly. The method below allows the pedal to be powered using a common standard modern 9V positive sleeve/negative center power supply.

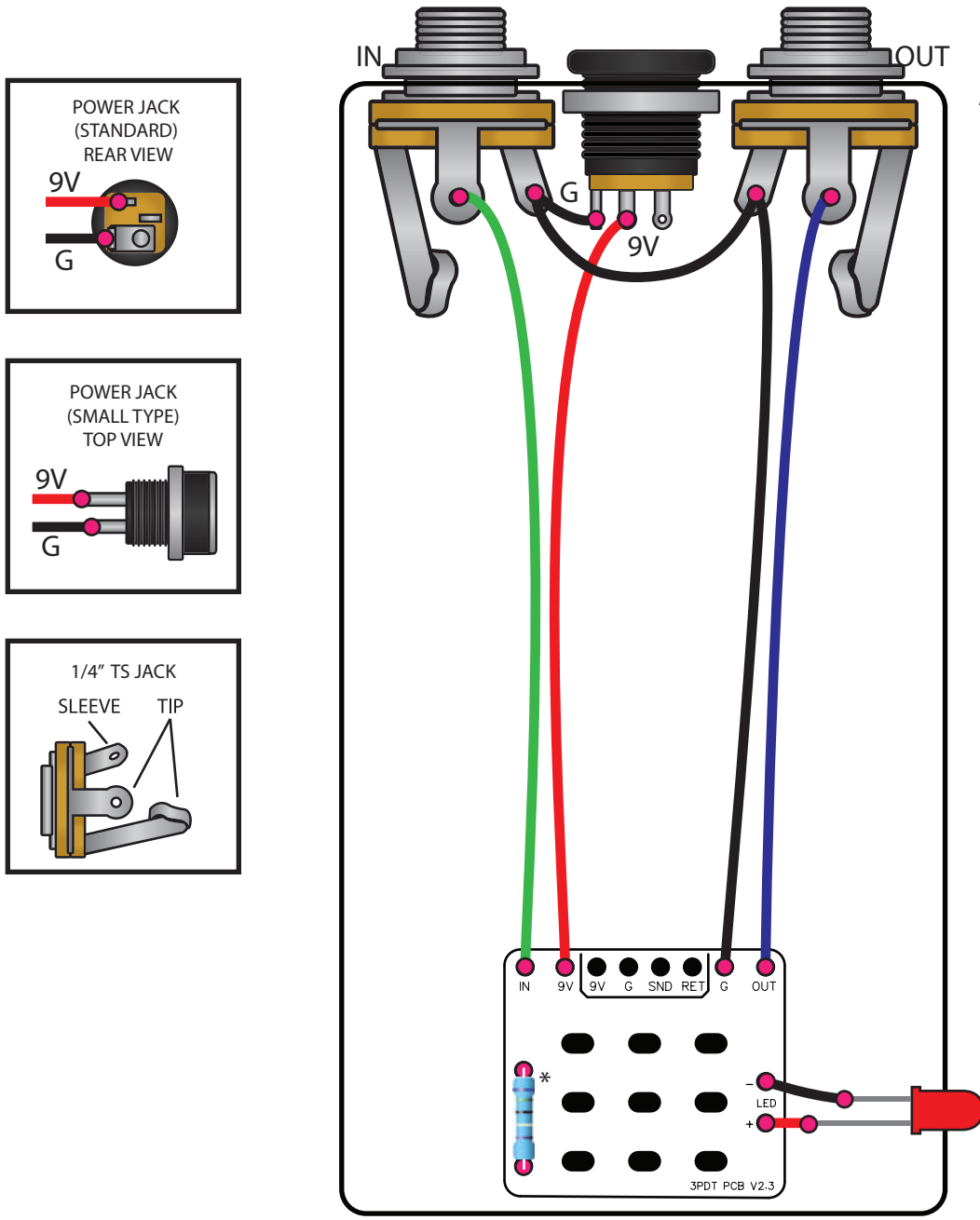

Audio jacks rotated for illustration purposes

NOTE:
If using a 3PDT PCB, it is easier to solder all wires and components first, and then solder the 3PDT switch to the board last.

● = Solder point

* LED resistor can be any value of your choice. Typical recommendation is 4.7k for normal red diffused LEDs, but may require up to 33k or so, depending on LED type and color.

The following wiring is recommended only if no 3PDT board is available. As long as the effect PCB receives the correct 9V, Ground, In, and Out connections, it will work properly. **A 3PDT PCB board is included with your effect PCB to simplify the offboard wiring process, if you would like to use the included 3PDT board, see page 8.** The offboard wiring method below allows the pedal to be powered using a common standard modern 9V positive sleeve/negative center power supply.

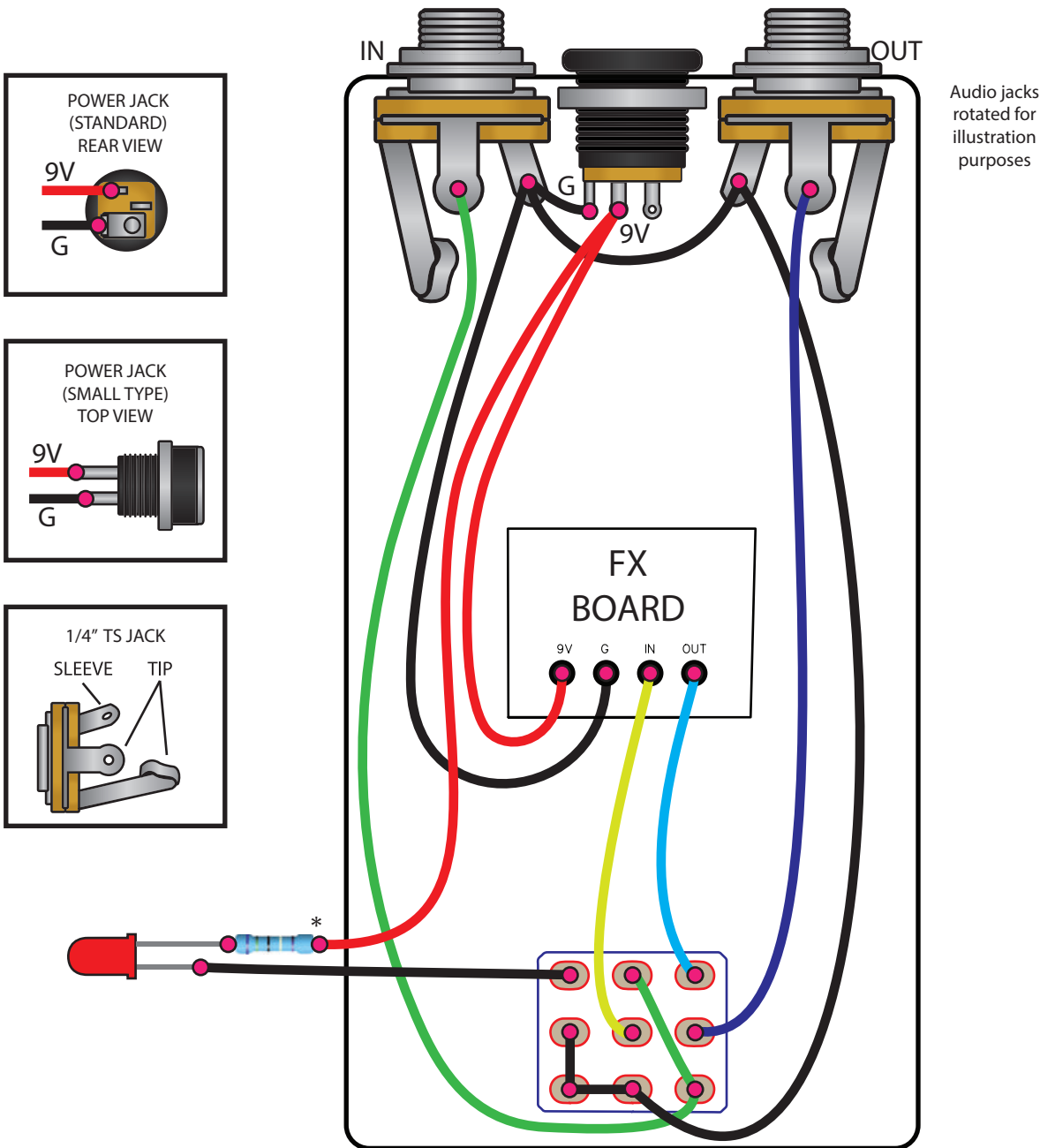

● = Solder point

* LED resistor can be any value of your choice. Typical recommendation is 4.7k for normal red diffused LEDs, but may require up to 33k or so, depending on LED type and color.

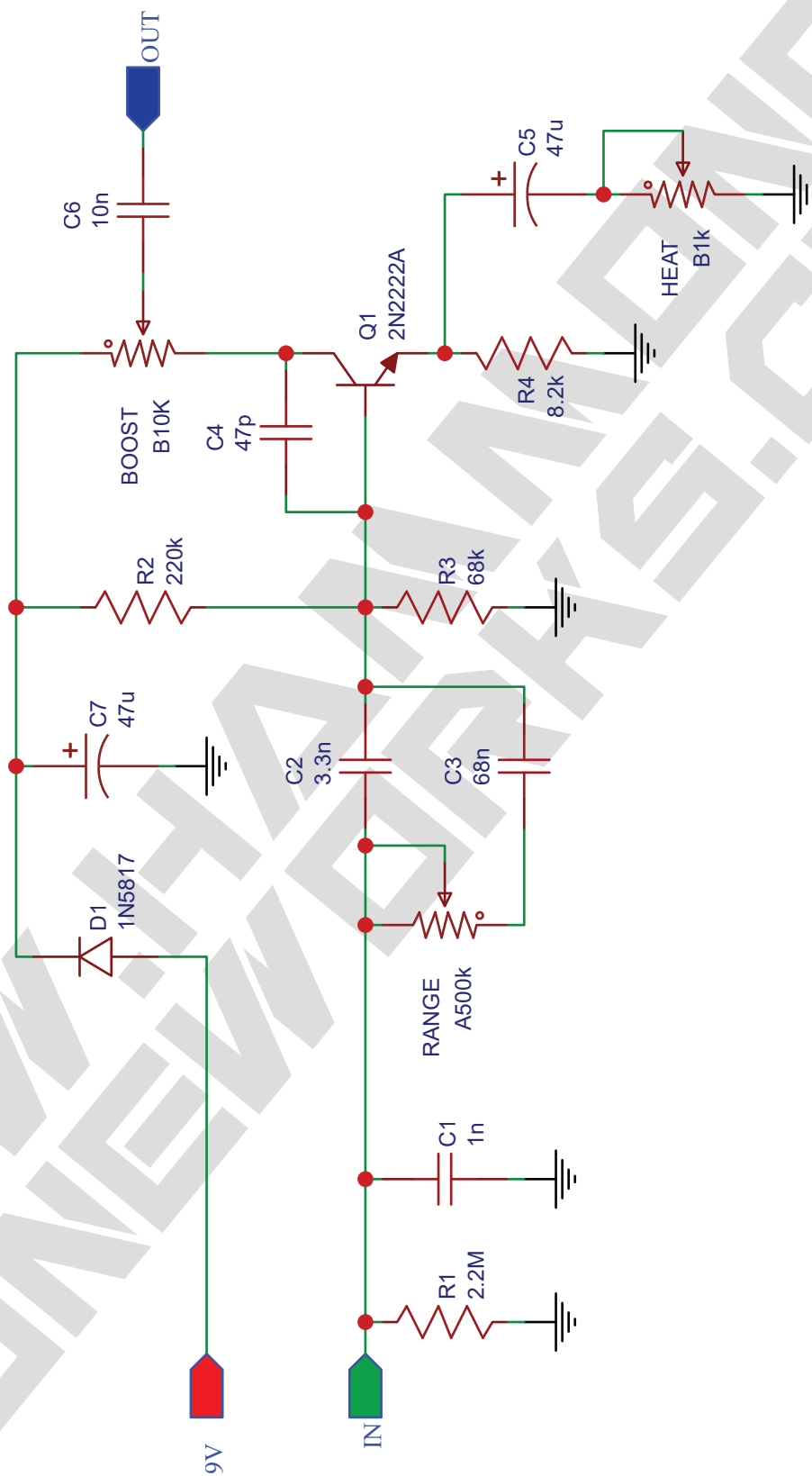

PRINT THIS PAGE ACTUAL SIZE

TAYDA DRILL TEMPLATE HT125B-3K-08 (small DC) HT125B-3K-12 (large DC)

125B Top Jack Drill Template Including drill size

DIRECTIONS:

1. Cut along dotted lines, and fold along the solid outline to preshape the paper template.

2. Carefully align template to the empty enclosure (without bottom lid) and tape in place to the enclosure.

You can also tape the corners of the template together once it is attached, to have a "cast" paper template ready if drilling more than one enclosure.

3. Using a steel punch, mark the drilling holes in the center of each cross. (mind the number of knobs) The punch should mark the enclosure even through the paper.

4. Remove template and check spacing on punched drill markers to ensure that everything will fit nicely. It's better to find out now than later. A common issue is the 1/4" jacks being too high, low, or offset. Hold a jack centered on the punch mark to see the clearance and make sure the lid will close (requires 2mm clearance from the open end of enclosure). Re-punch the drill markers if needed

5. Drill away!
Take your time. It's more rewarding to be patient and have a properly drilled enclosure than to rush and be out of alignment.

TIP:
After drilling, check your top jack fitment. Make sure you can fit both audio and power jacks in place properly. Top jacks are a tight fit, if one is off, bore out the hole slightly to get a good position if needed, no more than 1mm extra, as the external washer still needs to be able to have enough space around the hole to grab the enclosure.

Max knob diameter: 24mm

Note:
Some power jack diameters may be smaller than 12mm. Please refer to your preferred power jack spec sheet to find the diameter needed. The standard threaded DC jacks typically require a 12mm hole, and the smaller two prong DC jacks typically require an 8mm hole.

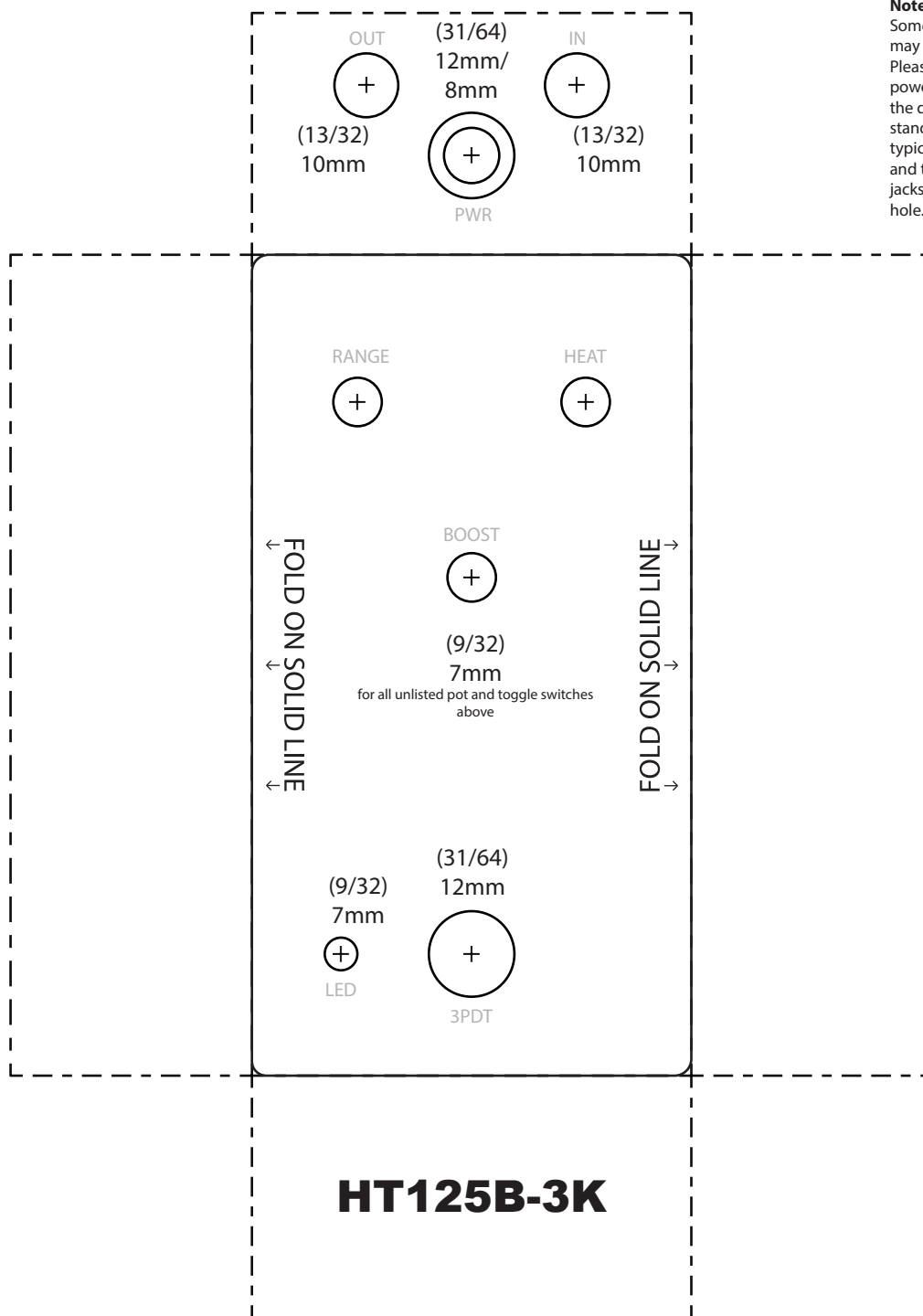

* This template and its measurements were calculated using manufacturer's specs and physically tested on Tayda branded size 125B enclosures.

Hammond Toneworks is in no way affiliated with Tayda Electronics